

## 2.4 Electromagnetism Homework Questions

1. A wind speed meter is designed as shown.

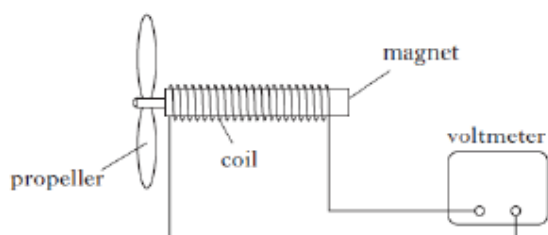

Air blows across the propeller causing the magnet to rotate. A voltage is induced across the coil. Which of the following changes will produce an increase in the induced voltage? (1)

- I. Replacing the magnet with one of greater field strength.
- II. Spinning the propeller faster.
- III. Reducing the number of turns on the coil.

- A. I only
- B. I and II only
- C. I and III only
- D. II and III only
- E. I, II and III

2. The diagram shows a model bicycle dynamo.

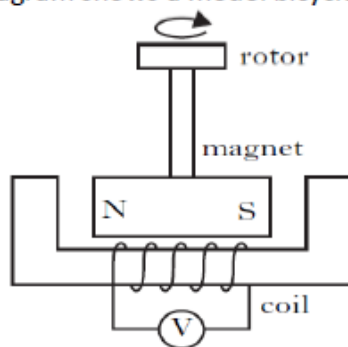

When the rotor is turned the magnet rotates, inducing a voltage in the coil. The induced voltage can be decreased by (1)

- A. increasing the number of turns on the coil
- B. decreasing the number of turns on the coil
- C. using a stronger magnet
- D. turning the rotor faster
- E. reversing the direction of rotation of the magnet.

3

When a magnet is pushed into or pulled out of a coil of wire, a voltage is induced across the ends of the coil.

(1)

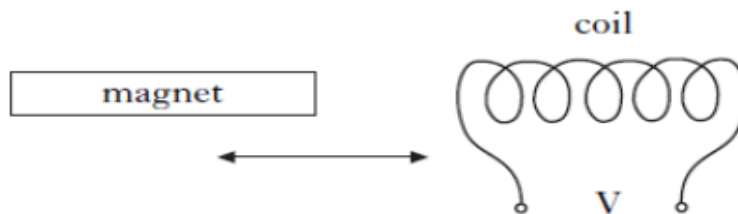

Which of the following produces the greatest induced voltage?

	<i>Strength of magnet</i>	<i>Speed of magnet</i>	<i>Number of turns in a coil</i>
A	weak	slow	20
B	weak	fast	40
C	strong	slow	20
D	strong	fast	20
E	strong	fast	40

4. A student uses a probe connected to ammeter to detect the magnetic field close to a coil of wire.

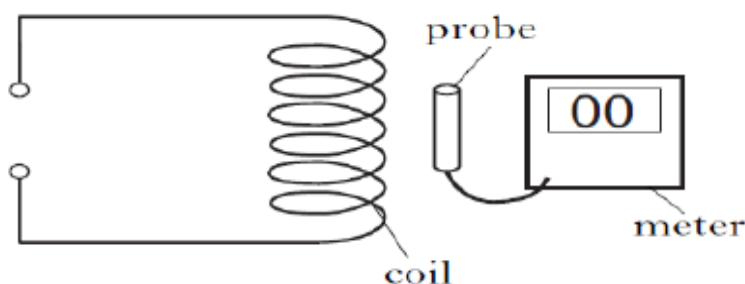

The reading on the meter is zero.

Which of the following will cause the reading on the meter to change?

(1)

- A. Decreasing the number of turns in the coil
- B. Increasing the number of turns in the coil
- C. Passing a current through the coil
- D. Replacing the coil with another coil made of thicker wire
- E. Replacing the coil with another coil made of thinner wire

5. Consider the diagram shown.

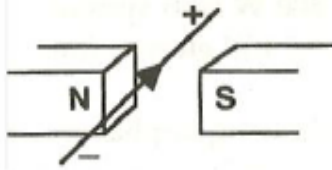

- a) What happens to the wire when current passes as shown? (1)
- b) What would happen to the wire if the direction of the current was reversed? (1)
- d) What would happen to the wire if the current and the magnetic field were reversed? (1)

6. This is a diagram of a simple electric motor.

- a) State 3 ways in which the coil could be made to rotate faster.
- b) What would happen if the battery was reversed?

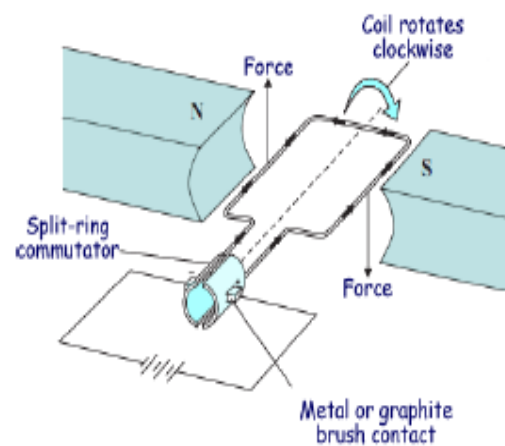

(4)

**Total Marks Available = 11**